





GUILIN ZHUONUO TECHNOLOGY CO.,LTD.

 Rm. 1206-1209, Block A, Landmark Financial Building, MixC, Guilin, China.

 +86 130 7766 8397

 +86 136 6773 2409

 www.glwinneo.com

 info@glwinneo.com



WeChat



WhatsApp

Custom WINNEO Pads
— Precision Substrate Fit for Pad Printing
Full Ink Pickup
Clean Release
Tough & Durable

Thousands of miles, a promise to never lose our original heart.

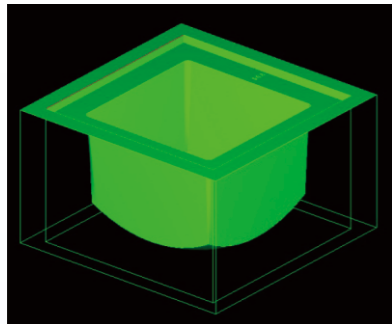
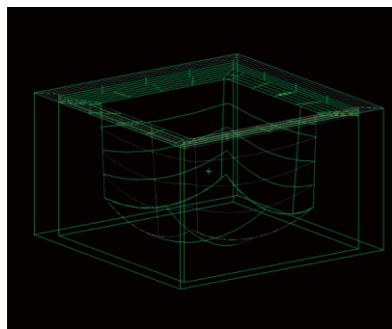

Pads play a crucial role in pad printing production. The printing quality of patterns largely depends on the quality of the pads and the manufacturing technology. WINNEO possesses mature design capabilities and manufacturing technology for pads and pad molds! From the selection, design, programming, and manufacturing of pad molds, to the precise proportioning of pad raw materials, bubble-free molding, mold release, and finished product packaging, we have a complete set of professional processes and production facilities. We can provide customers with fast and accurate professional pad design guidance, or clone any shape of pad or mold you need.

移印胶头在移印生产中担当着重要的角色，移印图案的印刷质量很大程度上取决于胶头的品质及制作技术，WINNEO具备成熟的移印胶头和胶头模具设计能力及制作技术！从胶头模具的选材、设计、编程、制作，到胶头原料的精确配比、无气泡倒模、起模成品包装，我们拥有整套专业的工艺流程及生产配套设施，可以为客户快速精准的提供专业的胶头设计指导，或者克隆您所需要的任何形状的胶头或模具。

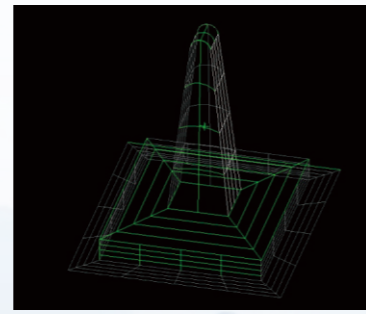
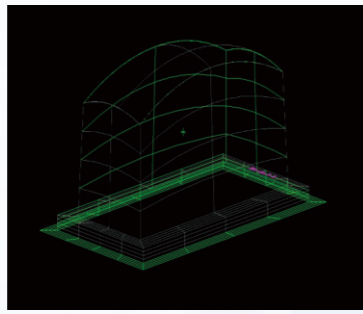
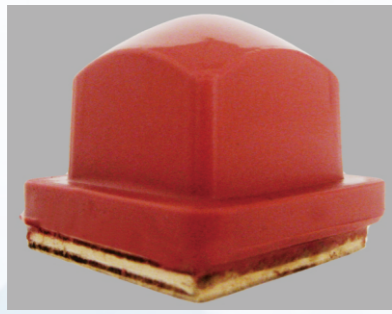
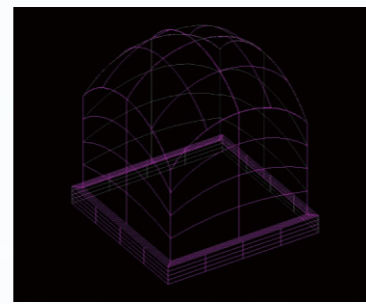
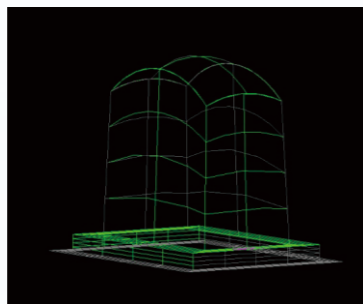
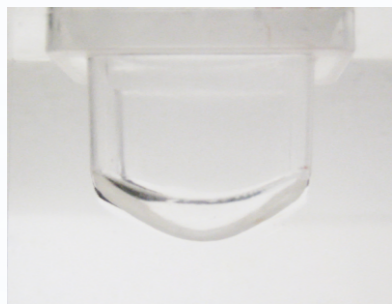

专业 · 严格 · 用心 · 精准

Professional Strict Focus Precise





WN-R01

Reference printing area (mm) ϕ 32
L76.5---W82---H76(mm)

WN-R06

Reference printing area (mm) ϕ 10
L103---W49---H78(mm)

WN-R02

Reference printing area (mm) ϕ 65
L150---W125---H76(mm)

WN-R07

Reference printing area (mm) ϕ 75
L114---W112---H70(mm)

WN-R03

Reference printing area (mm) ϕ 30
L81---W77---H76(mm)

WN-R08

Reference printing area (mm) ϕ 40
L77---W77---H76(mm)

WN-R04

Reference printing area (mm) ϕ 25
L76---W76---H63(mm)

WN-R09

Reference printing area (mm) ϕ 50
L94---W90---H70(mm)

WN-R05

Reference printing area (mm) ϕ 15
L108---W78---H60(mm)

WN-R10

Reference printing area (mm) ϕ 30
L72---W67---H52(mm)



WN-R11

Reference printing area (mm) ϕ 40
L88---W85---H70(mm)

WN-R16

Reference printing area (mm) ϕ 15
L180---W65---H40(mm)

WN-R12

Reference printing area (mm) ϕ 50
L87---W87---H64(mm)

WN-R17

Reference printing area (mm) ϕ 15
L180---W63---H41(mm)

WN-R13

Reference printing area (mm) ϕ 40
L79---W75---H65(mm)

WN-R18

Reference printing area (mm) ϕ 40
L81---W76---H76(mm)

WN-R14

Reference printing area (mm) ϕ 32
L76---W76---H75(mm)

WN-R19

Reference printing area (mm) ϕ 60
L102---W100---H75(mm)

WN-R15

Reference printing area (mm) ϕ 20
L75---W75---H70(mm)

WN-R20

Reference printing area (mm) ϕ 40
L92---W89---H70(mm)

★ 本页是移印胶头部分常用型号图，如果在此没有合适您的规格请提供给我们您的样板或图纸，以便我们为您订做。

★ if your pad models are not in this page, please inform us and provide us your sample or drawing, we can make it according to your request!

★ 本页是移印胶头部分常用型号图，如果在此没有合适您的规格请提供给我们您的样板或图纸，以便我们为您订做。

★ if your pad models are not in this page, please inform us and provide us your sample or drawing, we can make it according to your request!



WN-R21

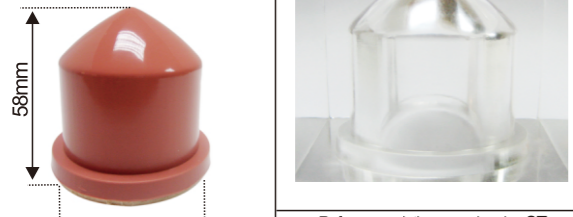

58mm
ø62mm

Reference printing area (mm) ø27
L80---W80---H60(mm)

WN-R26

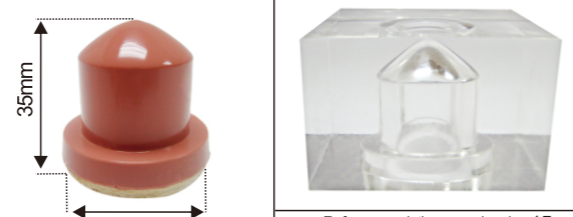

35mm
ø38.5mm

Reference printing area (mm) ø15
L65---W60---H40(mm)

WN-R22



47mm
ø56.5mm

Reference printing area (mm) ø32
L83---W80---H50(mm)

WN-Q01

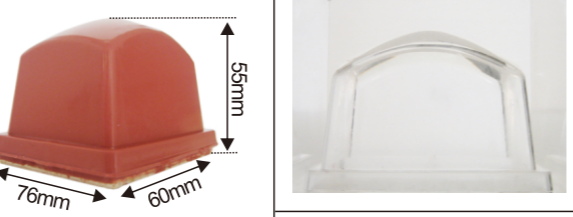

55mm
76mm 60mm

Reference printing area (mm) 50*35
L82---W77---H67(mm)

WN-R23

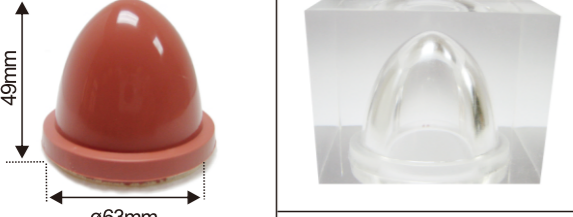

49mm
ø63mm

Reference printing area (mm) ø37
L80---W75---H60(mm)

WN-Q02

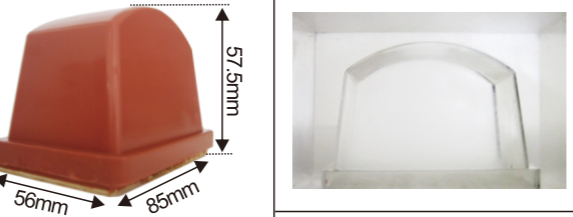

57.5mm
56mm 85mm

Reference printing area (mm) 55*30
L111---W70---H69(mm)

WN-R24



52mm
ø55mm

Reference printing area (mm) ø30
L75---W65---H60(mm)

WN-Q03

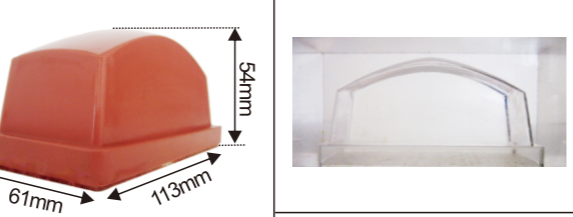

54mm
61mm 113mm

Reference printing area (mm) 85*36
L133---W82---H62(mm)

WN-R25



61mm
ø109mm

Reference printing area (mm) ø74
L135---W120---H65(mm)

WN-Q04

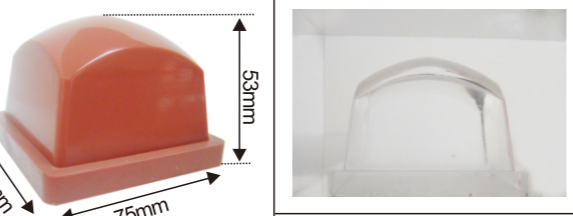

53mm
75mm 75mm

Reference printing area (mm) 50*50
L101---W95---H70(mm)



WN-Q05

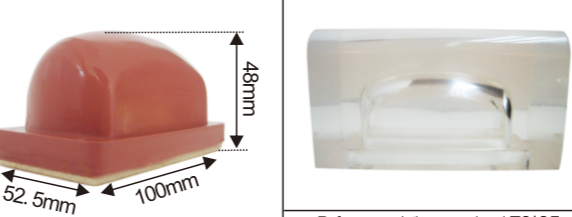

48mm
52.5mm 100mm

Reference printing area (mm) 70*35
L117---W82---H70.5(mm)

WN-Q10

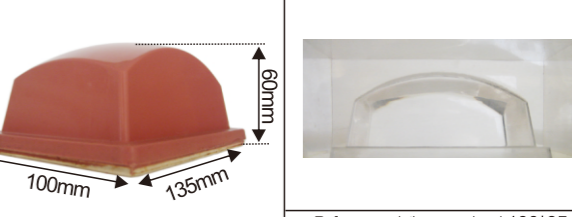

60mm
100mm 135mm

Reference printing area (mm) 100*65
L118---W112---H72(mm)

WN-Q06

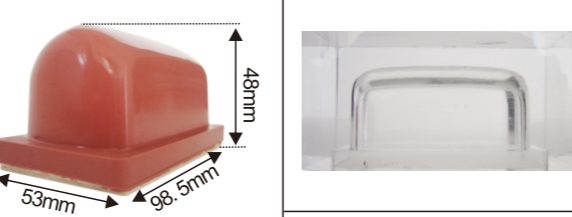

48mm
53mm 98.5mm

Reference printing area (mm) 65*65
L121---W83---H62.5(mm)

WN-Q11

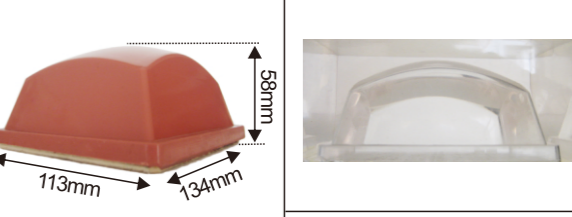

58mm
113mm 134mm

Reference printing area (mm) 80*60
L115---W114---H61.5(mm)

WN-Q07



61mm
ø96mm

Reference printing area (mm) ø60
L112---W111---H75(mm)

WN-Q12

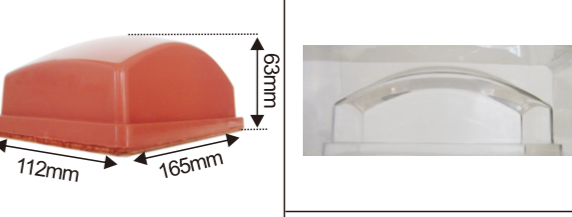

63mm
112mm 165mm

Reference printing area (mm) 130*80
L200---W113---H72(mm)

WN-Q08

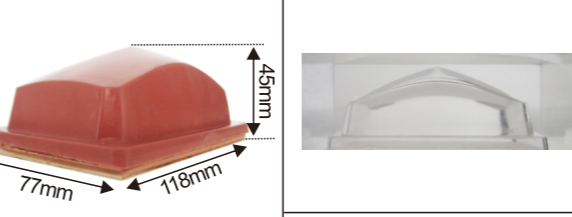

45mm
77mm 118mm

Reference printing area (mm) 90*50
L115---W112---H76(mm)

WN-Q13

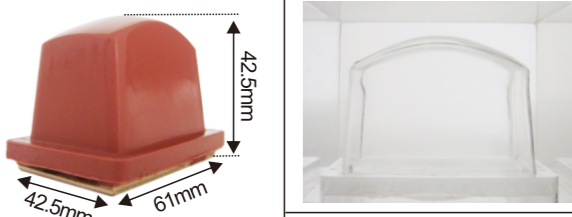

42.5mm
42.5mm 61mm

Reference printing area (mm) 30*20
L68---W66---H50(mm)

WN-Q09

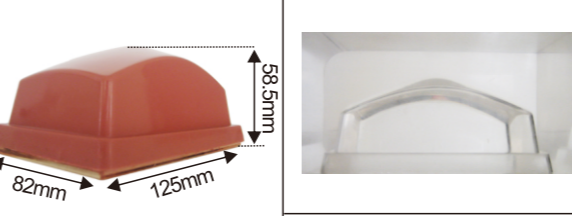

58.5mm
82mm 125mm

Reference printing area (mm) 90*52
L115---W111---H76(mm)

WN-Q14

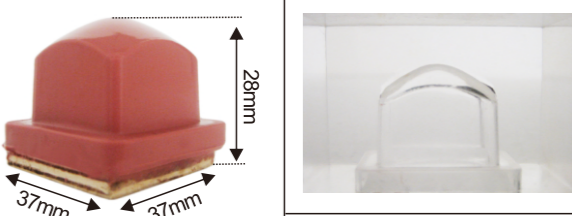

28mm
37mm 37mm

Reference printing area (mm) 12*12
L60---W49---H38(mm)

★ 本页是移印胶头部分常用型号图，如果在此没有合适您的规格请提供给我们您的样板或图纸，以便我们为您订做。
★ if your pad models are not in this page, please inform us and provide us your sample or drawing, we can make it according to your request!

★ 本页是移印胶头部分常用型号图，如果在此没有合适您的规格请提供给我们您的样板或图纸，以便我们为您订做。
★ if your pad models are not in this page, please inform us and provide us your sample or drawing, we can make it according to your request!



WN-Q15

Reference printing area (mm) 50*35
L110---W91---H70(mm)

WN-Q20

Reference printing area (mm) 58*41
L98---W80---H75(mm)

WN-Q16

Reference printing area (mm) 65*50
L110---W95---H60(mm)

WN-Q21

Reference printing area (mm) 69*59
L90---W80---H57(mm)

WN-Q17

Reference printing area (mm) 55*20
L105---W75---H50(mm)

WN-Q22

Reference printing area (mm) 95*65
L160---W135---H75(mm)

WN-Q18

Reference printing area (mm) 10*5
L50---W40---H45(mm)

WN-T01

Reference printing area (mm) 120*50
L245---W245---H45(mm)

WN-Q19

Reference printing area (mm) 75*55
L135---W111---H75(mm)

WN-L01

Reference printing area (mm) 65*50
L114---W91---H89(mm)



WN-L02

Reference printing area (mm) 70*25
L112---W48---H48(mm)

WN-L07

Reference printing area (mm) 300*20
L350---W55---H50(mm)

WN-L03

Reference printing area (mm) 75*10
L105---W72---H40(mm)

WN-L08

Reference printing area (mm) 290*50
L350---W92---H64(mm)

WN-L04

Reference printing area (mm) 370*57
L455---W125---H160(mm)

WN-L09

Reference printing area (mm) 320*40
L375---W89---H71(mm)

WN-L05

Reference printing area (mm) 120*50
L117---W95---H60(mm)

WN-L10

Reference printing area (mm) 290*45
L340---W85---H70(mm)

WN-L06

Reference printing area (mm) 305*20
L365---W60---H52(mm)

WN-L11

Reference printing area (mm) 305*15
L400---W70---H60(mm)

★ 本页是移印胶头部分常用型号图，如果在此没有合适您的规格请提供给我们您的样板或图纸，以便我们为您订做。
★ if your pad models are not in this page, please inform us and provide us your sample or drawing, we can make it according to your request!

★ 本页是移印胶头部分常用型号图，如果在此没有合适您的规格请提供给我们您的样板或图纸，以便我们为您订做。
★ if your pad models are not in this page, please inform us and provide us your sample or drawing, we can make it according to your request!

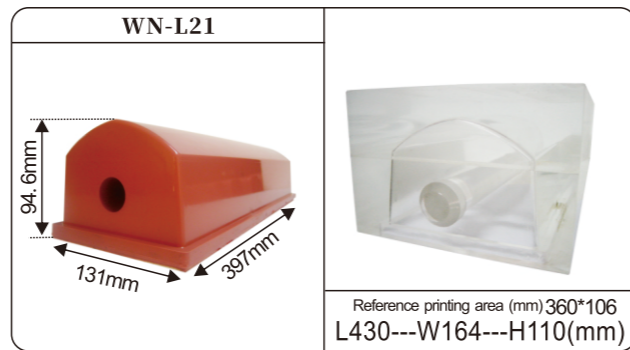
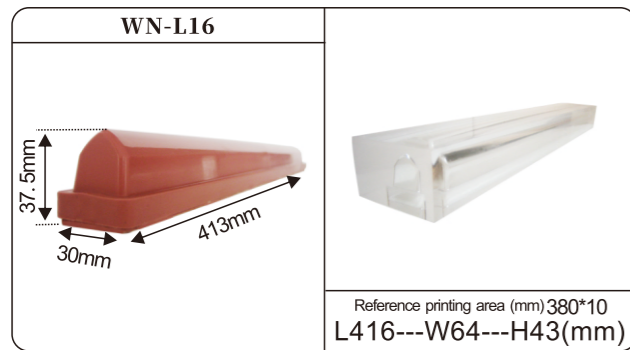
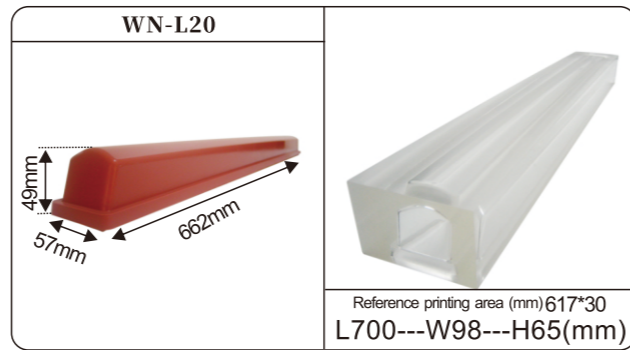
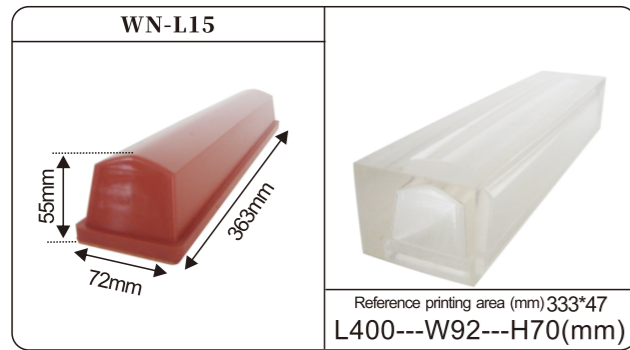
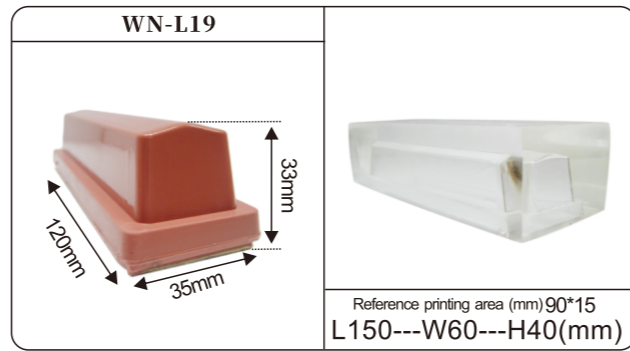
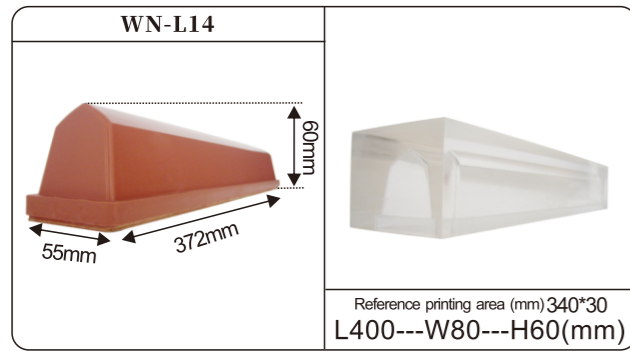
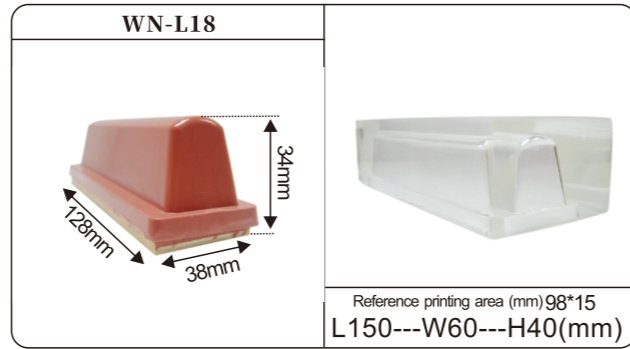
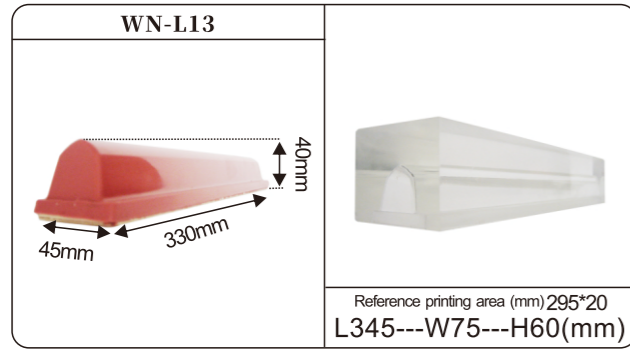
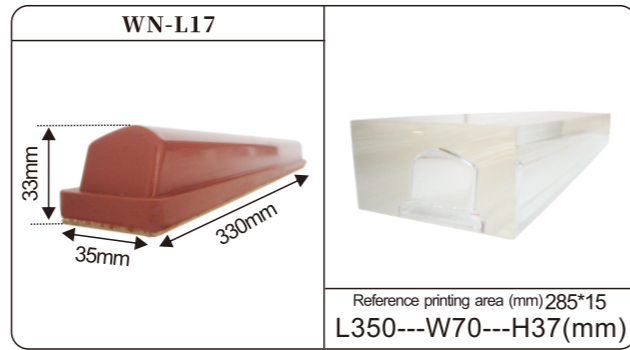
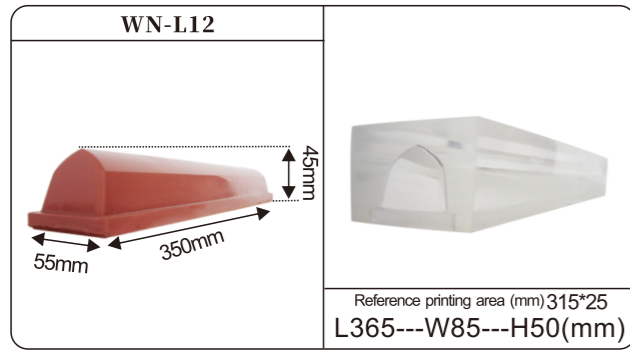

★ 本页是移印胶头部分常用型号图，如果在此没有合适您的规格请提供给我们您的样板或图纸，以便我们为您订做。
★ if your pad models are not in this page, please inform us and provide us your sample or drawing, we can make it according to your request!

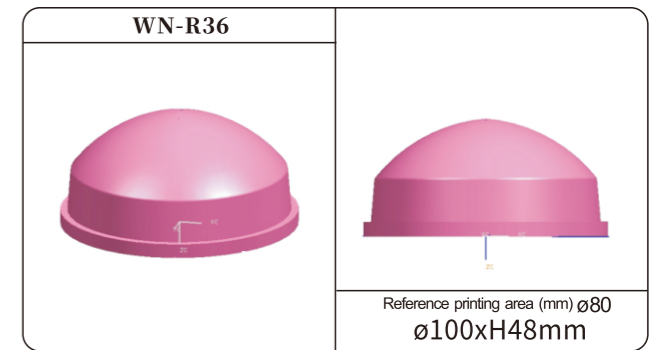
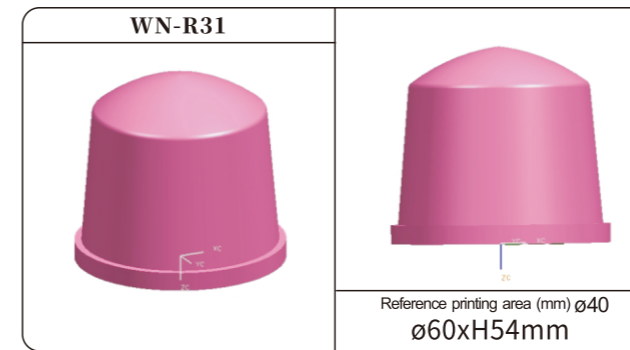
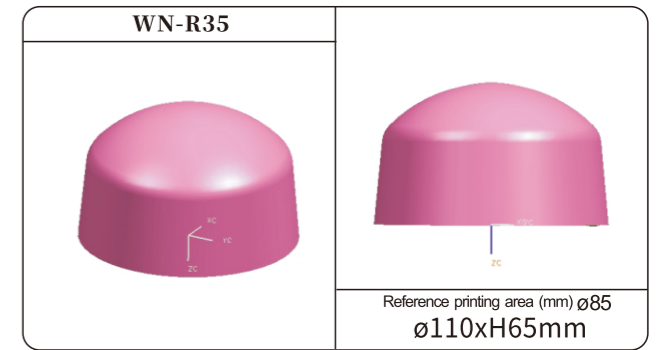
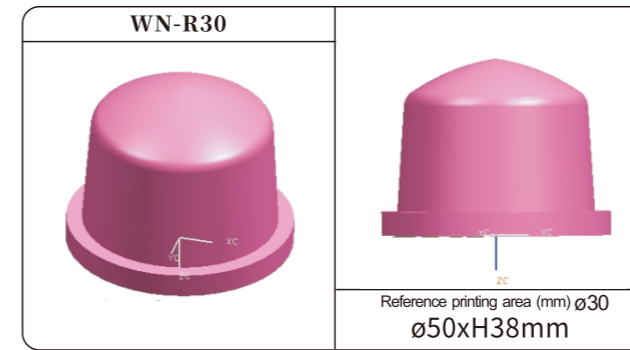
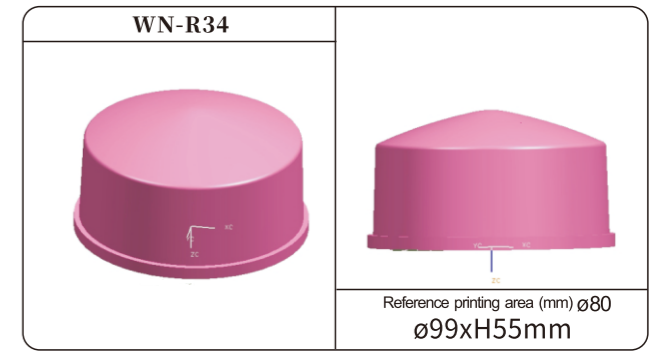
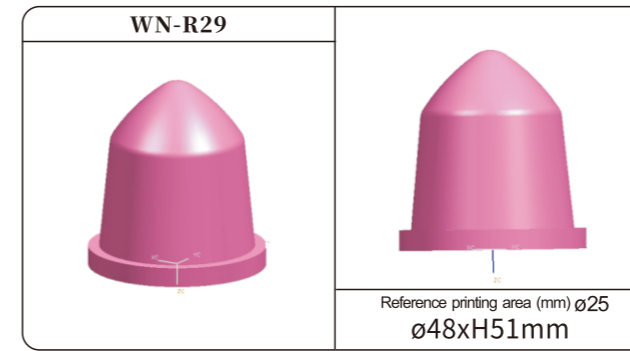
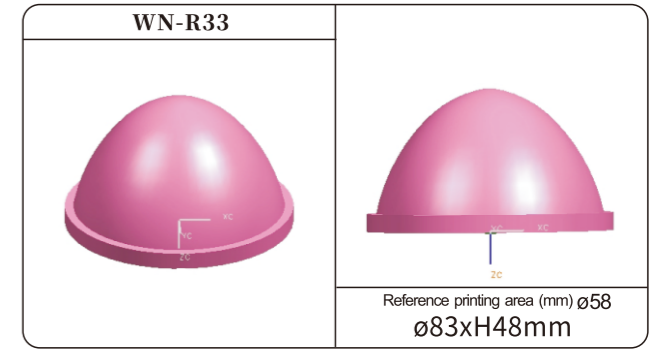
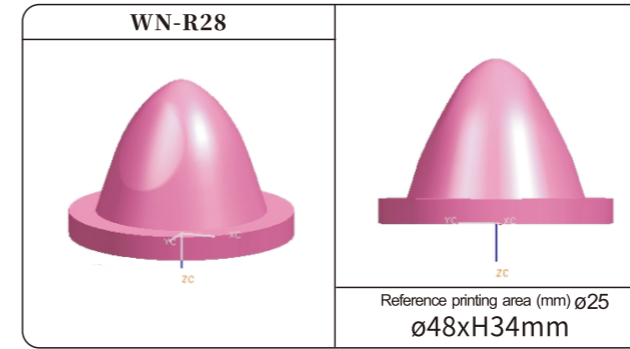
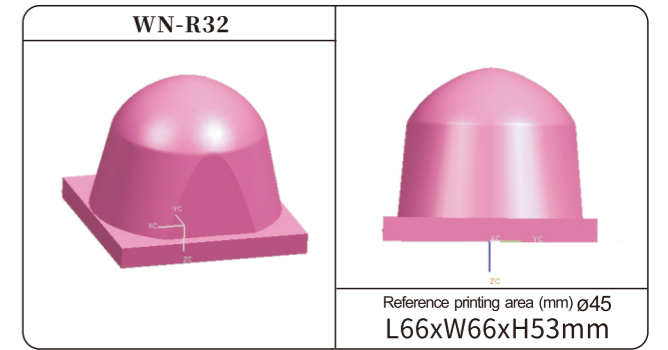
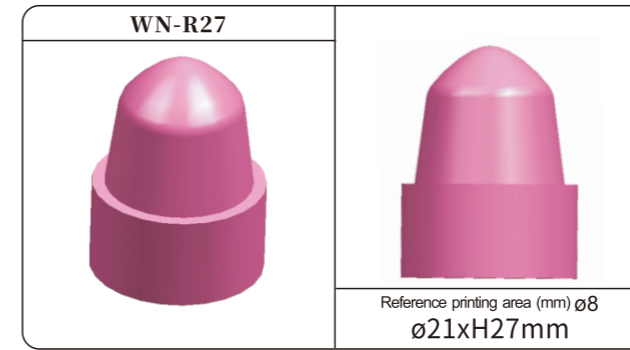











★ 本页是移印胶头部分常用型号图，如果在此没有合适您的规格请提供给我们您的样板或图纸，以便我们为您订做。
★ if your pad models are not in this page, please inform us and provide us your sample or drawing, we can make it according to your request!

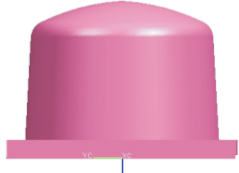
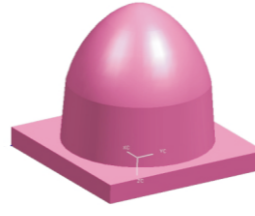
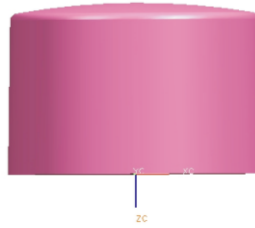

<p>WN-R37</p> 	 <p>Reference printing area (mm) $\phi 5$ $\phi 15 \times H 18 \text{mm}$</p>	<p>WN-R42</p> 	 <p>Reference printing area (mm) $\phi 6$ $\phi 18 \times H 18 \text{mm}$</p>
<p>WN-R38</p> 	 <p>Reference printing area (mm) $\phi 5$ $\phi 16 \times H 17 \text{mm}$</p>	<p>WN-R43</p> 	 <p>Reference printing area (mm) $\phi 10$ $\phi 20 \times H 40 \text{mm}$</p>
<p>WN-R39</p> 	 <p>Reference printing area (mm) $\phi 4$ $\phi 17 \times H 20 \text{mm}$</p>	<p>WN-R44</p> 	 <p>Reference printing area (mm) $\phi 19$ $\phi 33 \times H 37 \text{mm}$</p>
<p>WN-R40</p> 	 <p>Reference printing area (mm) $\phi 6$ $\phi 18 \times H 18 \text{mm}$</p>	<p>WN-R45</p> 	 <p>Reference printing area (mm) $\phi 20$ $\phi 42 \times H 34 \text{mm}$</p>
<p>WN-R41</p> 	 <p>Reference printing area (mm) $\phi 6$ $\phi 18 \times H 18 \text{mm}$</p>	<p>WN-R46</p> 	 <p>Reference printing area (mm) $\phi 15$ $\phi 50 \times H 39 \text{mm}$</p>

★ 本页是移印胶头部分常用型号图，如果在此没有合适您的规格请提供给我们您的样板或图纸，以便我们为您订做。
★ if your pad models are not in this page, please inform us and provide us your sample or drawing, we can make it according to your request!

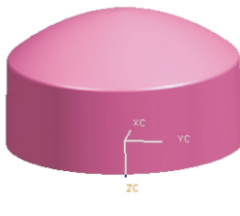

<p>WN-R47</p> 	 <p>Reference printing area (mm) $\phi 33$ $\phi 53 \times H 37 \text{mm}$</p>	<p>WN-R52</p> 	 <p>Reference printing area (mm) $\phi 32$ $\phi 65 \times H 45 \text{mm}$</p>
<p>WN-R48</p> 	 <p>Reference printing area (mm) $\phi 35$ $\phi 57 \times H 49 \text{mm}$</p>	<p>WN-R53</p> 	 <p>Reference printing area (mm) $\phi 40$ $L 66 \times W 66 \times H 45 \text{mm}$</p>
<p>WN-R49</p> 	 <p>Reference printing area (mm) $\phi 27$ $L 47 \times W 47 \times H 42 \text{mm}$</p>	<p>WN-R54</p> 	 <p>Reference printing area (mm) $\phi 68$ $\phi 72 \times H 48 \text{mm}$</p>
<p>WN-R50</p> 	 <p>Reference printing area (mm) $\phi 40$ $\phi 61 \times H 61 \text{mm}$</p>	<p>WN-R55</p> 	 <p>Reference printing area (mm) $\phi 50$ $\phi 81 \times H 56 \text{mm}$</p>
<p>WN-R51</p> 	 <p>Reference printing area (mm) $\phi 40$ $\phi 61 \times H 52 \text{mm}$</p>	<p>WN-R56</p> 	 <p>Reference printing area (mm) $\phi 70$ $\phi 88 \times H 50 \text{mm}$</p>

★ 本页是移印胶头部分常用型号图，如果在此没有合适您的规格请提供给我们您的样板或图纸，以便我们为您订做。
★ if your pad models are not in this page, please inform us and provide us your sample or drawing, we can make it according to your request!

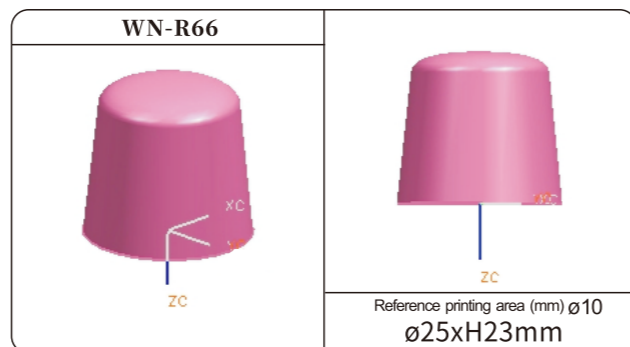
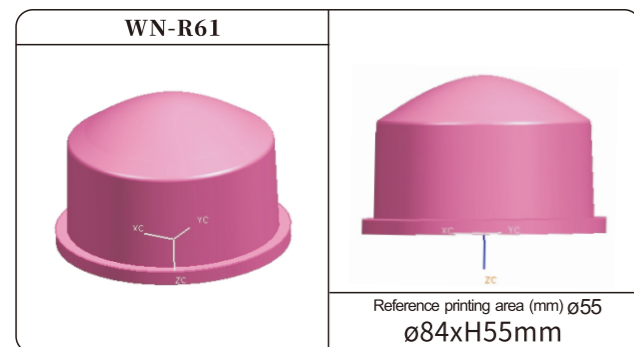
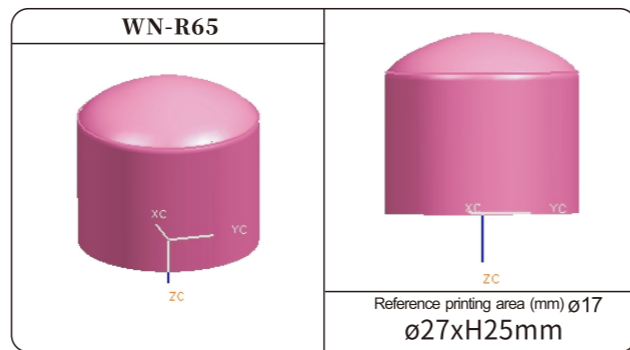
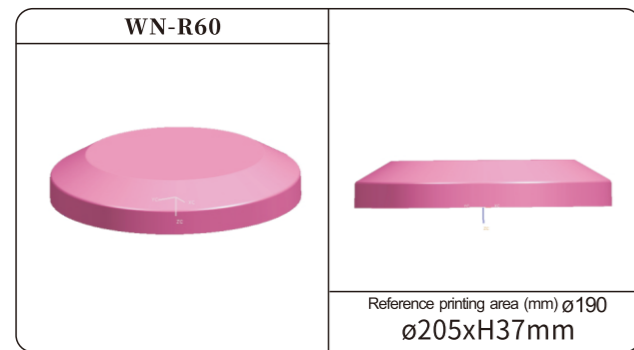
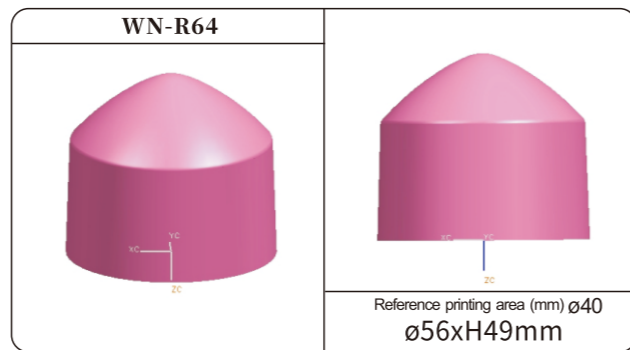
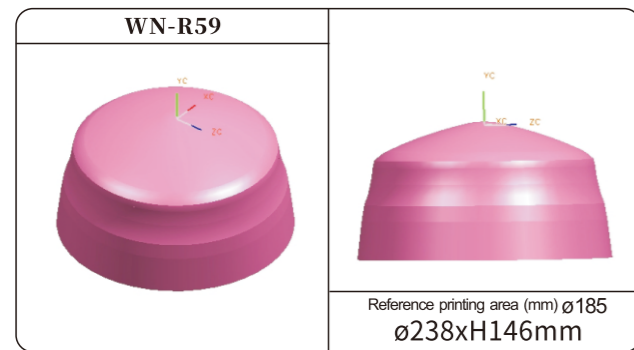
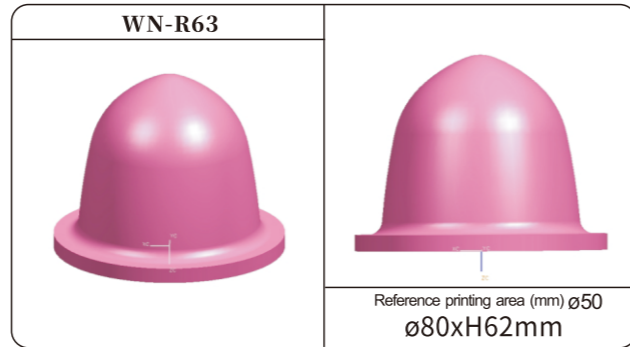
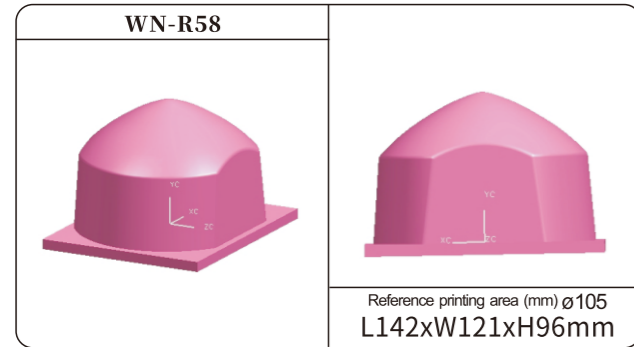
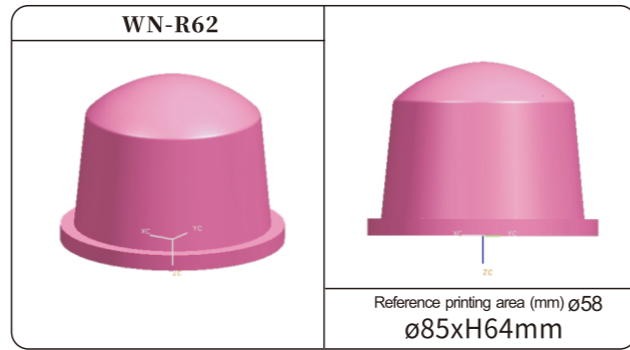
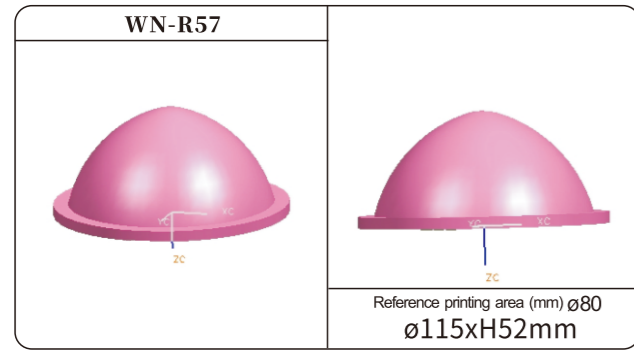

★ 本页是移印胶头部分常用型号图，如果在此没有合适您的规格请提供给我们您的样板或图纸，以便我们为您订做。
★ if your pad models are not in this page, please inform us and provide us your sample or drawing, we can make it according to your request!

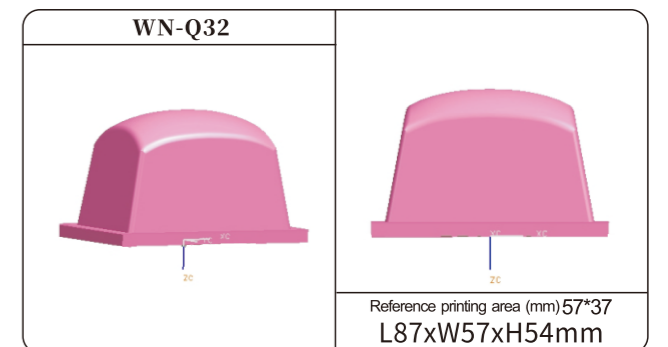
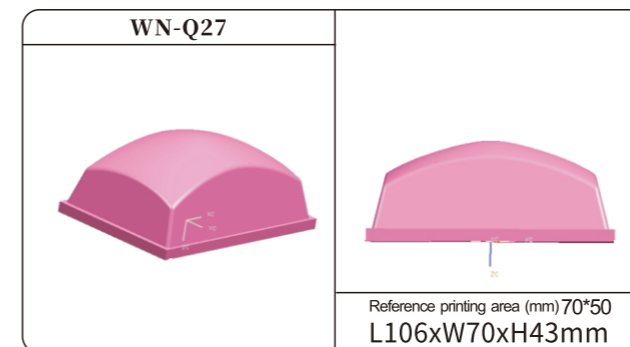
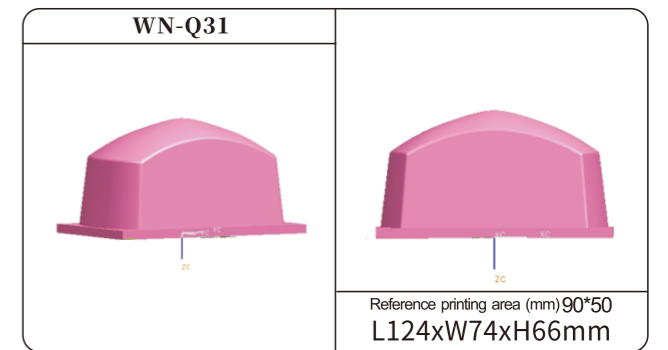
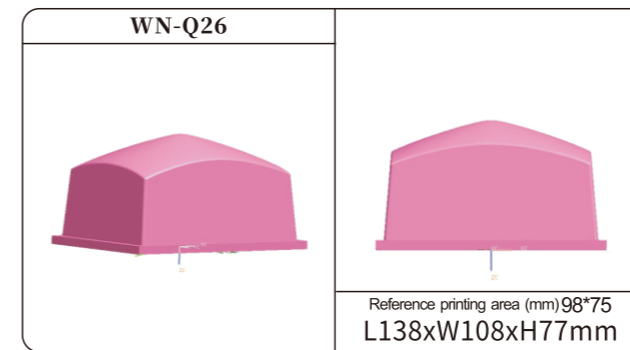
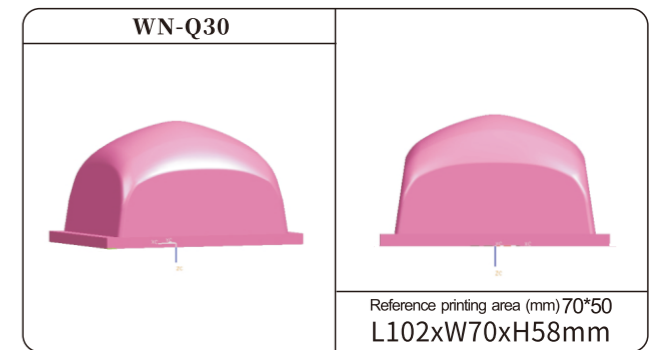
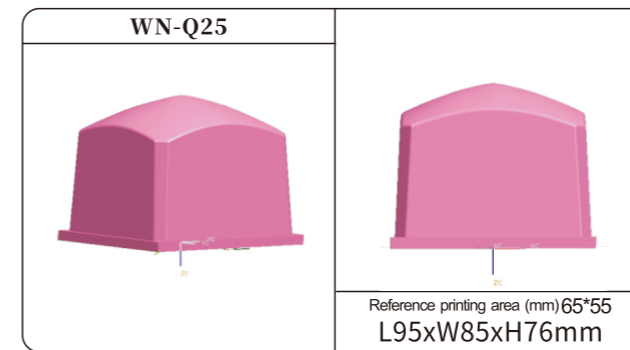
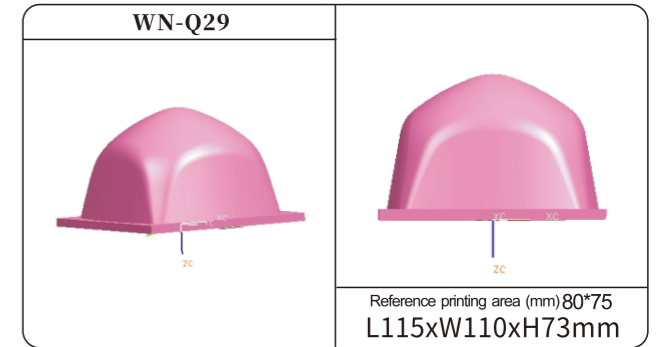
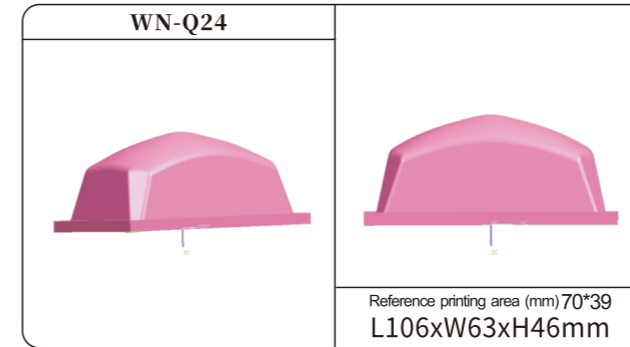
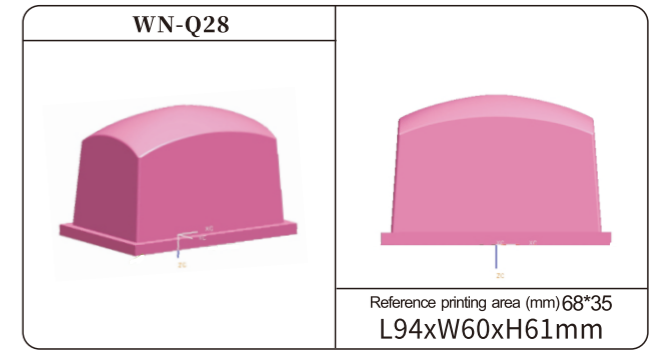
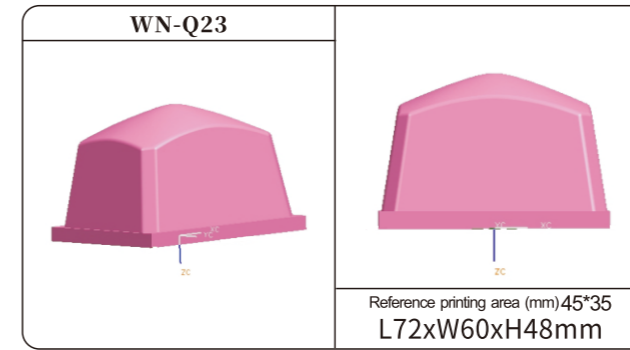

★ 本页是移印胶头部分常用型号图，如果在此没有合适您的规格请提供给我们您的样板或图纸，以便我们为您订做。
★ if your pad models are not in this page, please inform us and provide us your sample or drawing, we can make it according to your request!

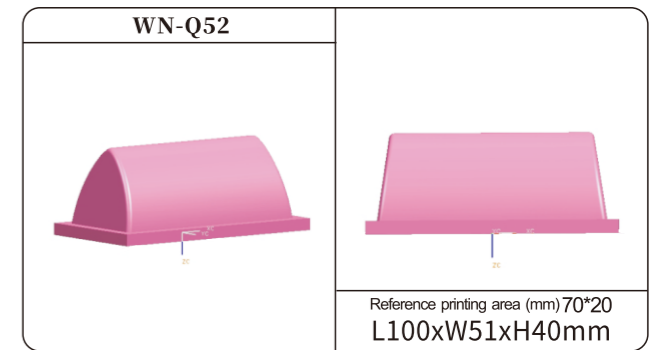
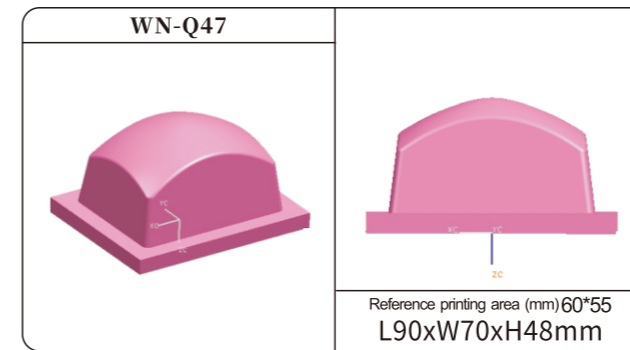
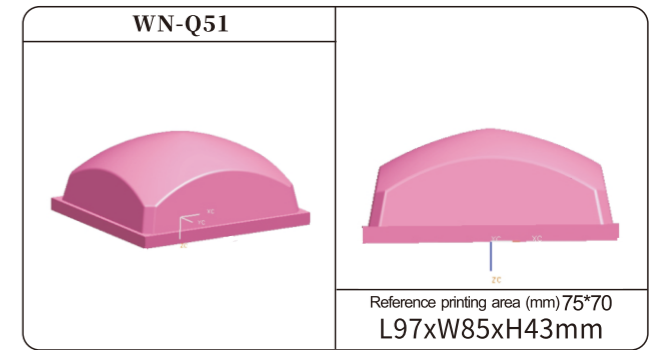
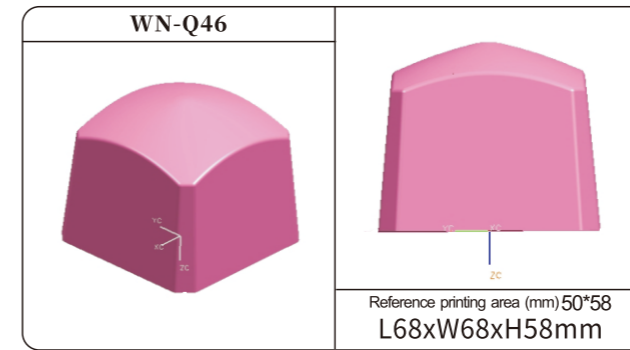
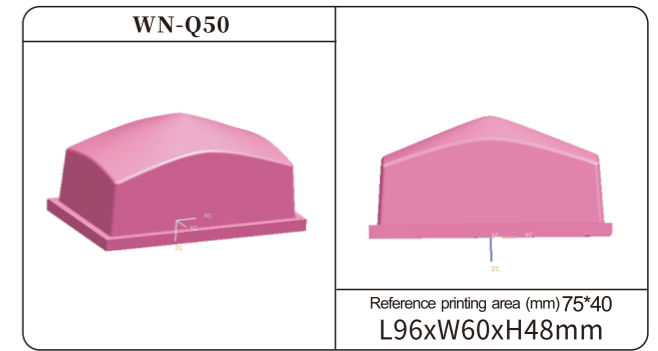
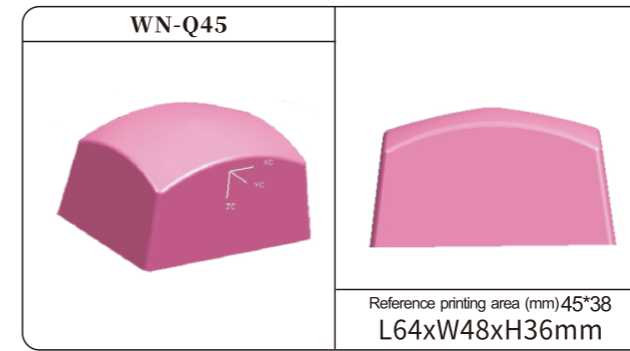
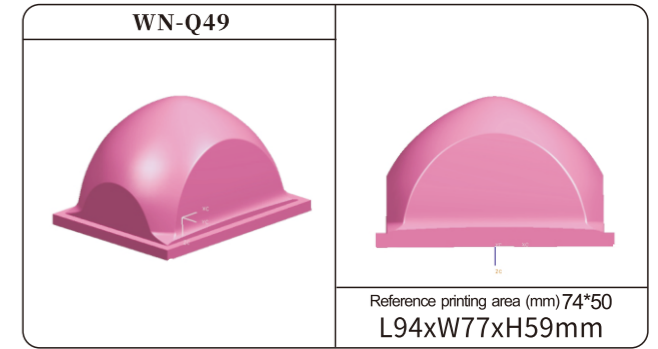
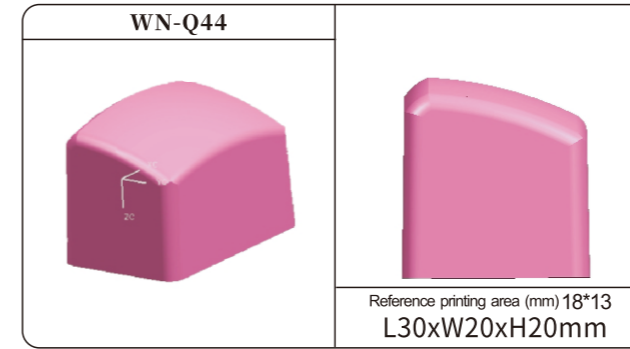
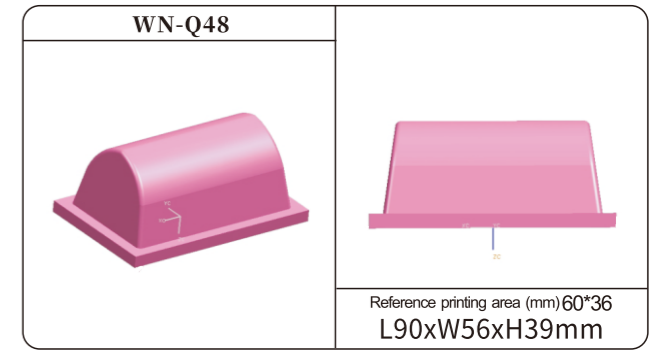
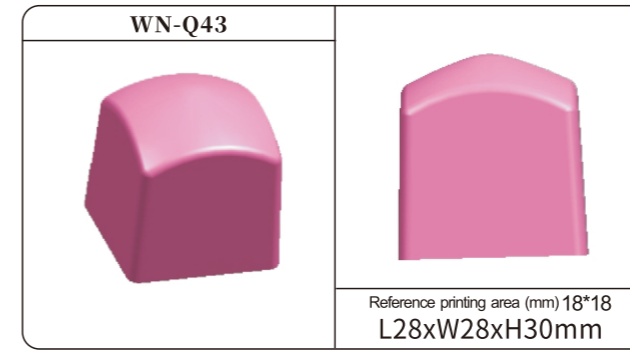
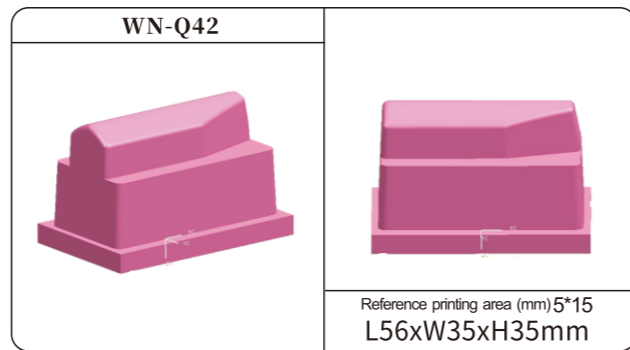
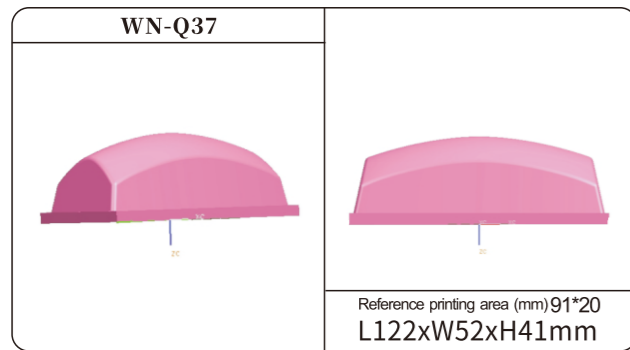
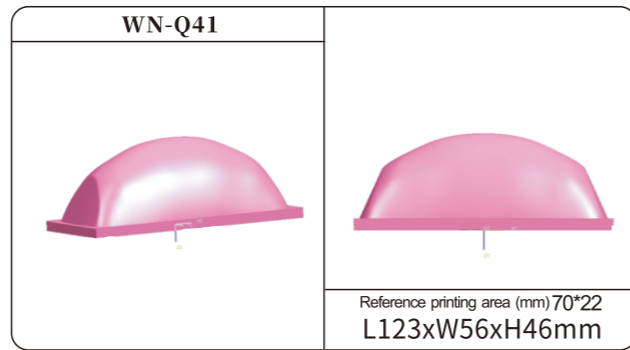
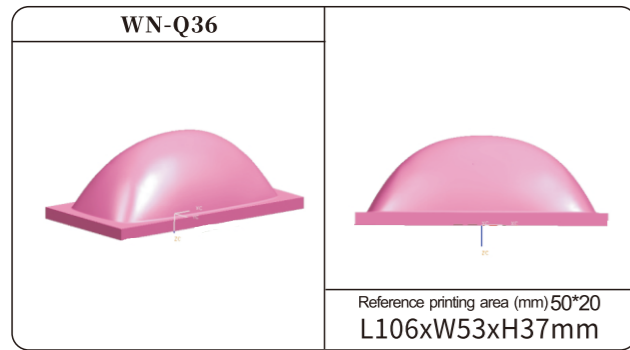
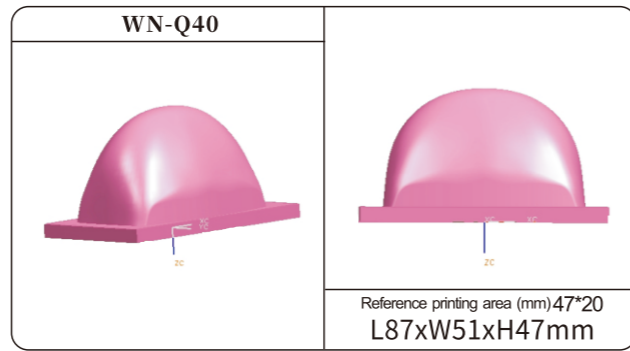
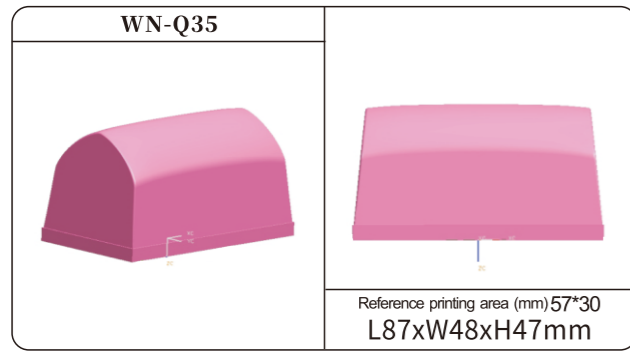
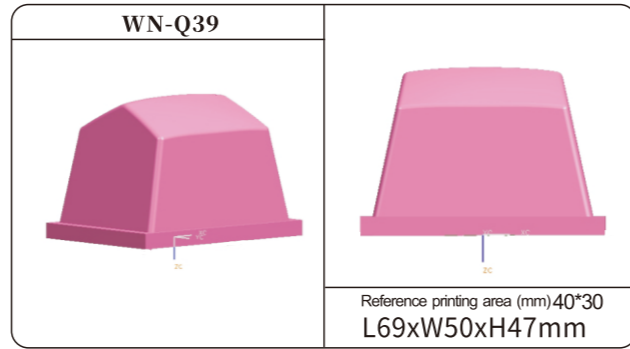
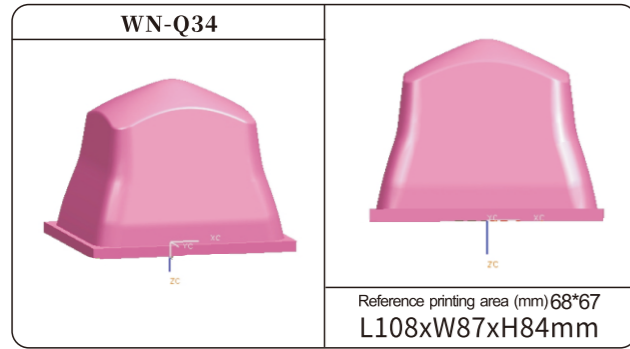
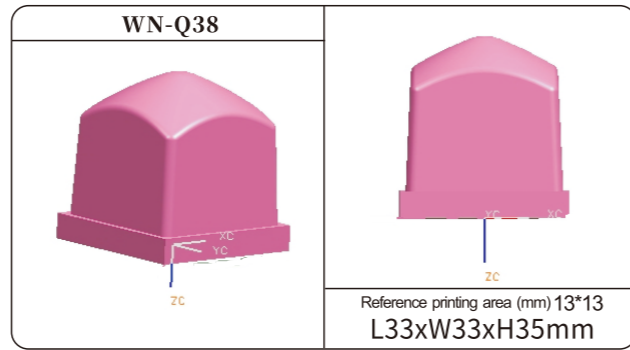
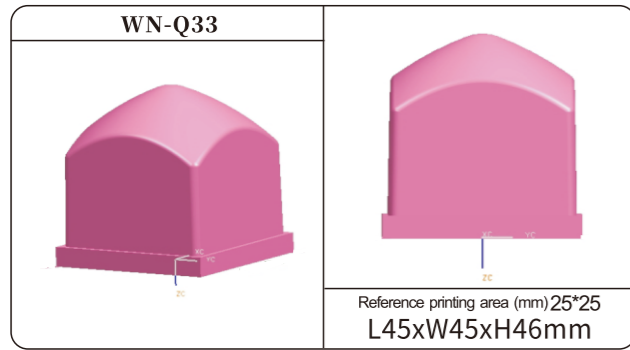

★ 本页是移印胶头部分常用型号图，如果在此没有合适您的规格请提供给我们您的样板或图纸，以便我们为您订做。
★ if your pad models are not in this page, please inform us and provide us your sample or drawing, we can make it according to your request!

★ 本页是移印胶头部分常用型号图，如果在此没有合适您的规格请提供给我们您的样板或图纸，以便我们为您订做。
★ if your pad models are not in this page, please inform us and provide us your sample or drawing, we can make it according to your request!



WN-Q53

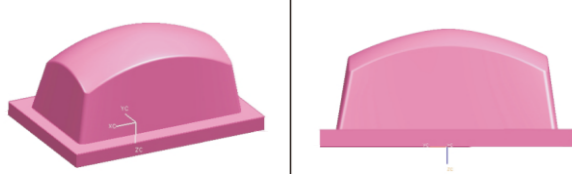

Reference printing area (mm) 78*50
L108xW70xH50mm

WN-Q58

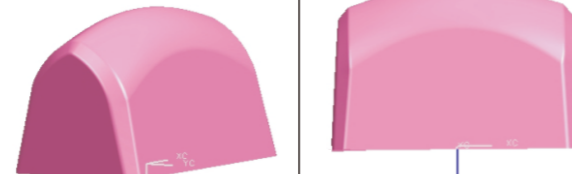

Reference printing area (mm) 37*20
L57xW38xH37mm

WN-Q54

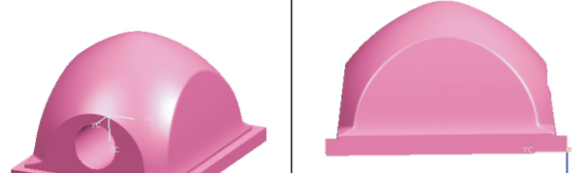

Reference printing area (mm) 60*45
L93xW77xH59mm

WN-Q59



Reference printing area (mm) 72*45
L102xW75xH54mm

WN-Q55

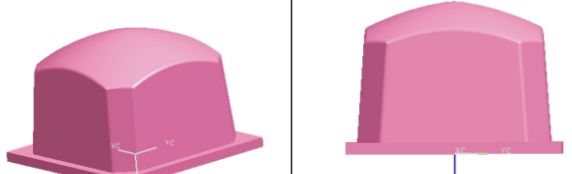

Reference printing area (mm) 72*73
L98xW98xH68mm

WN-Q60

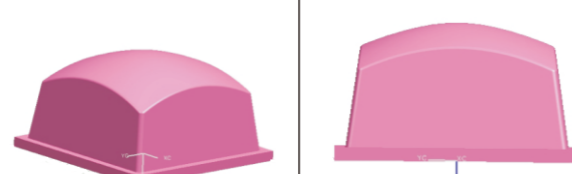

Reference printing area (mm) 84*84
L114xW114xH64mm

WN-Q56

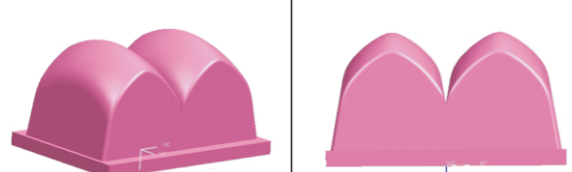

Reference printing area (mm) (75*19)*2
L101xW74xH56mm

WN-Q61

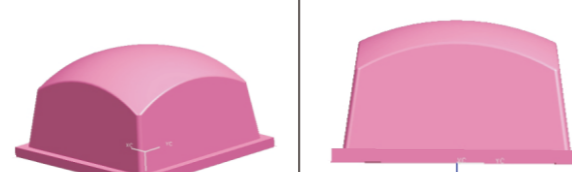

Reference printing area (mm) 84*84
L114xW114xH65mm

WN-Q57

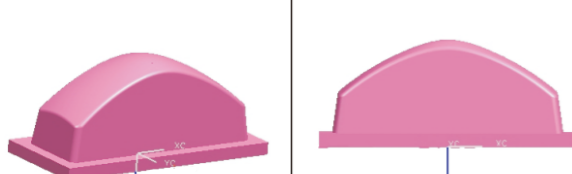

Reference printing area (mm) 60*22
L100xW42xH41mm

WN-Q62

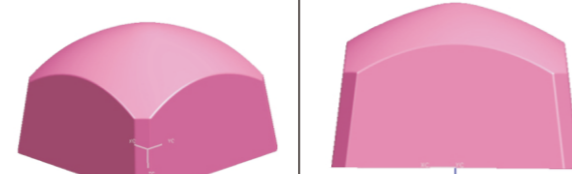

Reference printing area (mm) 100*100
L119xW119xH79mm



WN-Q63

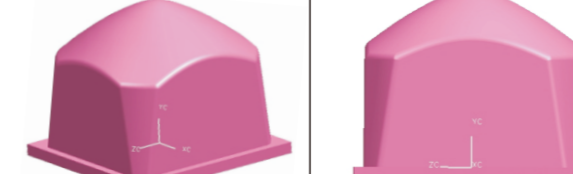

Reference printing area (mm) 95*80
L118xW106xH97mm

WN-Q68

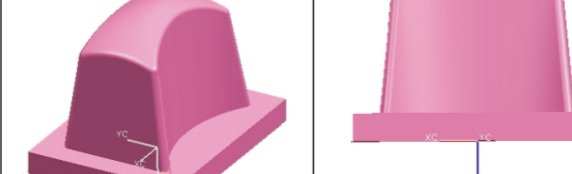

Reference printing area (mm) 17*12
L47xW36xH34mm

WN-Q64

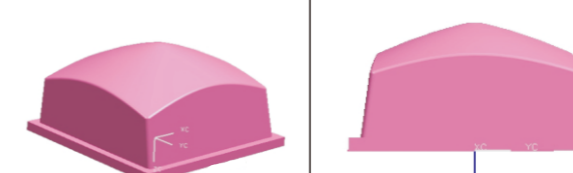

Reference printing area (mm) 92*92
L122xW122xH65mm

WN-Q69

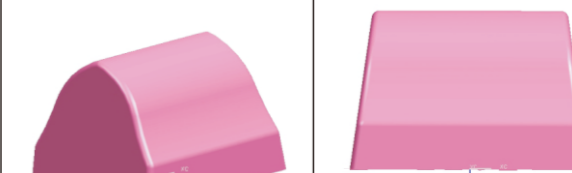

Reference printing area (mm) 33*30
L48xW58xH38mm

WN-Q65

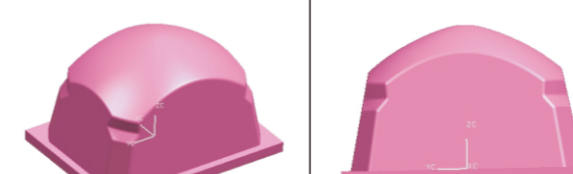

Reference printing area (mm) 100*65
L130xW97xH81mm

WN-Q70

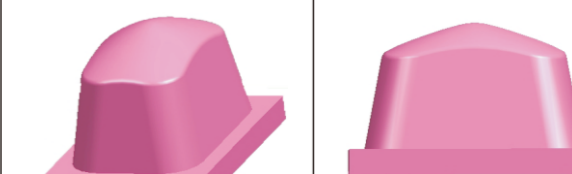

Reference printing area (mm) 30*15
L50xW35xH30mm

WN-Q66

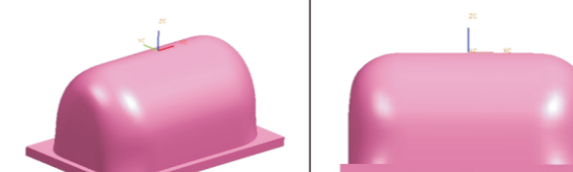

Reference printing area (mm) 125*70
L160xW102xH77mm

WN-Q71

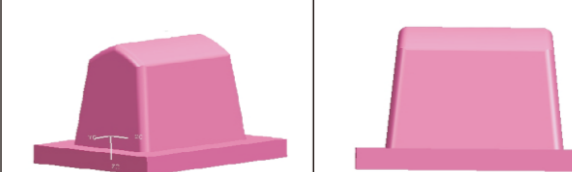

Reference printing area (mm) 32*20
L57xW45xH35mm

WN-Q67

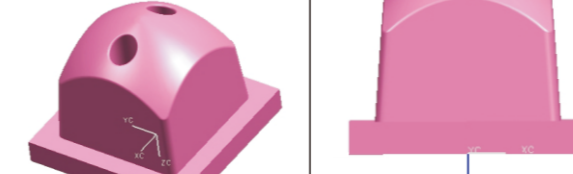

Reference printing area (mm) 20*20
L45xW45xH38mm

WN-Q72

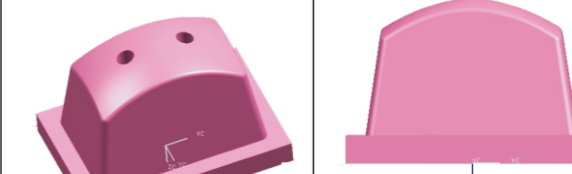

Reference printing area (mm) 37*18
L63xW44xH41mm



★ 本页是移印胶头部分常用型号图，如果在此没有合适您的规格请提供给我们您的样板或图纸，以便我们为您订做。



★ if your pad models are not in this page, please inform us and provide us your sample or drawing, we can make it according to your request!

★ 本页是移印胶头部分常用型号图，如果在此没有合适您的规格请提供给我们您的样板或图纸，以便我们为您订做。

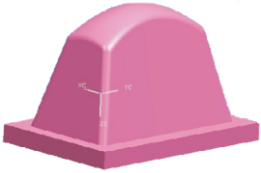

★ if your pad models are not in this page, please inform us and provide us your sample or drawing, we can make it according to your request!



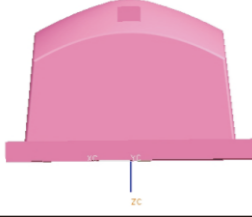

WN-Q73		
Reference printing area (mm) 38*18 L63xW41xH40mm		

WN-Q78		
Reference printing area (mm) 15*15 L55xW38xH34mm		

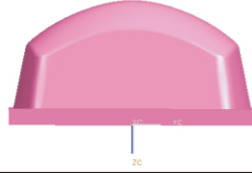

WN-Q74		
Reference printing area (mm) 40*40 L66xW66xH43mm		



WN-Q79		
Reference printing area (mm) 35*30 L60xW54xH42mm		

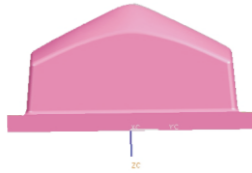

WN-Q75		
Reference printing area (mm) 55*25 L78xW51xH39mm		

WN-Q80		
Reference printing area (mm) 50*22 L78xW52xH38mm		

WN-Q76		
Reference printing area (mm) 40*22 L75xW52xH38mm		



WN-Q81		
Reference printing area (mm) 88*38 L113xW58xH49mm		

WN-Q77		
Reference printing area (mm) (30*37)*2 L105xW62xH57mm		

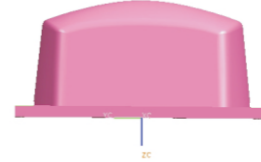

WN-Q82		
Reference printing area (mm) 85*40 L114xW66xH58mm		

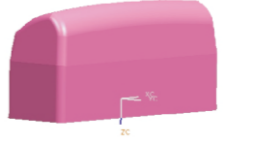

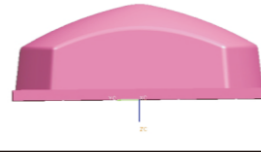

WN-Q83		
Reference printing area (mm) 85*45 L115xW74xH53mm		

WN-L25		
Reference printing area (mm) 32*8 L42xW13xH20mm		

WN-Q84		
Reference printing area (mm) 96*66 L126xW91xH47mm		

WN-L26		
Reference printing area (mm) 32*10 L62xW28xH23mm		

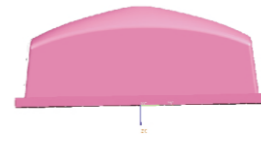

WN-L22		
Reference printing area (mm) 94*48 L134xW78xH60mm		

WN-L27		
Reference printing area (mm) 40*18 L65xW31xH37mm		

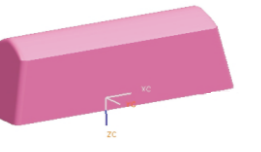
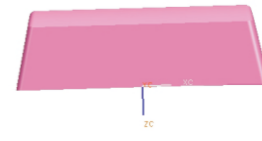
WN-L23		
Reference printing area (mm) 110*50 L140xW74xH54mm		

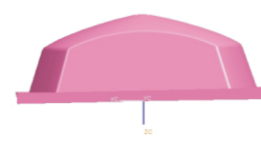
WN-L28		
Reference printing area (mm) 64*16 L84xW27xH26mm		

WN-L24		
Reference printing area (mm) 107*57 L147xW97xH50mm		



WN-L29		
Reference printing area (mm) 55*21 L90xW30xH25mm		

★ 本页是移印胶头部分常用型号图，如果在此没有合适您的规格请提供给我们您的样板或图纸，以便我们为您订做。
★ if your pad models are not in this page, please inform us and provide us your sample or drawing, we can make it according to your request!

★ 本页是移印胶头部分常用型号图，如果在此没有合适您的规格请提供给我们您的样板或图纸，以便我们为您订做。
★ if your pad models are not in this page, please inform us and provide us your sample or drawing, we can make it according to your request!





WN-L30



Reference printing area (mm) 61*20
L91xW28xH38mm

WN-L35

Reference printing area (mm) 140*45
L165xW65xH63mm

WN-L31



Reference printing area (mm) 93*39
L103xW43xH46mm

WN-L36

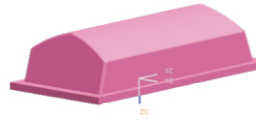
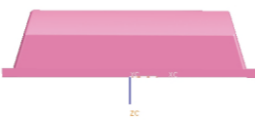

Reference printing area (mm) 120*65
L168xW88xH43mm

WN-L32



Reference printing area (mm) 105*34
L136xW57xH60mm

WN-L37



Reference printing area (mm) 190*25
L210xW46xH38mm

WN-L33



Reference printing area (mm) 120*35
L146xW60xH62mm

WN-L38

Reference printing area (mm) 200*42
L235xW67xH80mm

WN-L34

Reference printing area (mm) 120*35
L146xW60xH60mm

WN-L39



Reference printing area (mm) 1050*40
L1120xW60xH50mm

胶头抽真空机

VACUUMING UNIT FOR PAD MAKING

设备型号 (Machine model)	EN-ZK01
电压/电流 (Machine Power)	380V/50Hz
功率 (Pump Power)	1.5KW
抽气速率 (Pumping Rate)	15L/S
真空箱尺寸 (Work Space Size)	L:545mm W:375mm H:290mm



curing agent

silicone rubber

silicone oil

★ 本页是移印胶头部分常用型号图，如果在此没有合适您的规格请提供给我们您的样板或图纸，以便我们为您订做。

★ if your pad models are not in this page, please inform us and provide us your sample or drawing, we can make it according to your request!